

# Solar irradiation graphs

Thanos N. Stasinopoulos

*National Technical University of Athens, Greece*

## ABSTRACT

A common rule of thumb in solar applications is that maximum solar input on a flat collector comes when facing towards the equator at a slope equal to the location's latitude. Strict adherence to this rule leads frequently to layouts of questionable aesthetics, with the solar element detached from the geometry of the building in the name of '*optimum performance*'. An analytical study of solar irradiation on a plane as a function of its orientation and slope has shown that this rule can be disregarded to certain extent at a negligible energy shortfall. This is illustrated by a set of graphs, which show monthly radiation values for any orientation & slope in Athens. The set consists of 12 monthly graphs, one based on annual sums and one for the heating season, presenting the seasonal variations of solar intensity at various directions. The graphs can also be an easy tool for estimating the solar load imposed on vertical building surfaces at random orientation.

## 1. INTRODUCTION

Solar irradiation on a plane is primarily a function of its *orientation* and *tilt*. A *movable* collector offers the highest possible solar harvest by being continuously perpendicular to the solar rays. *Fixed* collectors -which are used in most solar applications- are usually positioned facing the equator at a slope equal to the location's latitude, following the practical rule for maximum efficiency.

Strict adherence to this rule leads frequently to layouts of questionable aesthetics, with the solar element detached from the geometry of the building in the name of '*optimum performance*' -a typical example of the conflict between architectural and engineering priorities.

On the other hand, the '*optimum orientation*' is sometimes blocked by nearby obstructions - from trees to mountains- that hinder solar collection. In such a case it might be better to twist the collector towards a direction with better solar access, or perhaps to change its slope, or both. Similarly, if the collector is to be attached on a roof that does not provide the '*optimum*' orientation and/or slope, one might wish to sacrifice a bit of efficiency for the sake of aesthetics.

What exactly would be the effect of such '*unorthodox*' practice on the solar input of the collector?

Apart from that, how can one estimate the solar load imposed on, say, a vertical building surface -like a wall or window- at orientation other than *south* (which is the only orientation for which radiation data is available in most locations)?

## 2. IRRADIATION VARIATIONS

### 2.1 An analytical study

The effects of orientation and slope on solar irradiation can be illustrated by the distribution of solar irradiation on a hemispherical *dome*, where each point faces towards a distinct direction. Stasinopoulos (1999) has carried out such an analytical study, considering a dome-like polyhedron [Fig. 1].

The study was based on the algorithm proposed by Page (1986) for the calculation of solar irradiation on tilted planes. Extensive computations were made for Athens, London and Riyadh, for average sky conditions. Calculated output was normalized to match measured horizontal radiation data. More details are given by Stasinopoulos (1999).

### 2.2 Major findings

That study has shown the extend to which orientation and tilt can deviate from '*optimum*' at a negligible penalty in terms of solar collection [Fig. 2]. True, equatorial orientation offers maximum solar input all year round, but '*a little to the east or west*' has fairly limited effect. The optimum slope varies each month, but again '*a little up or down*' can be insignificant in energy terms -perhaps even smaller than the effects of other factors like shading or reflectivity of the surroundings.

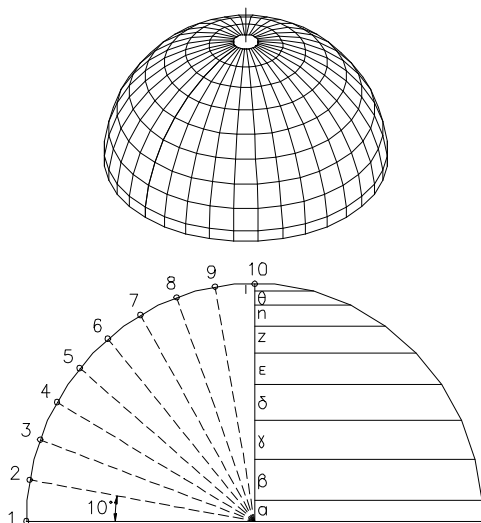

Fig. 1: A multi-facet dome with 9 rows of 19 facets each (= 171 facets) with orientation & tilt at steps of 10°.

## 3. IRRADIATION DISTRIBUTION GRAPHS

### 3.1 Summary

Data from the irradiation distribution study has been used to construct polar graphs that show daily energy values on planes of any orientation & slope in a manner similar to polar sun path diagrams [Fig. 3].

Each graph consists of closed curves that refer to all points on a dome having the same *slope* at steps of 30 or 10 degrees. The distance of a point from the centre of the graph indicates solar energy incident daily on a plane at the particular orientation and slope.

### 3.2 Description of the graphs

The set presented here refers to daily global irradiation in Athens for average sky conditions and ground albedo 0.2. It includes 12 monthly graphs, plus one for the daily average during the entire year and one during the heating period, i.e. when mean ambient temperature is below 20°C (November to April). The annual graphs are useful for all-year solar applications like domestic water heating or PV, and the winter ones for space heating.

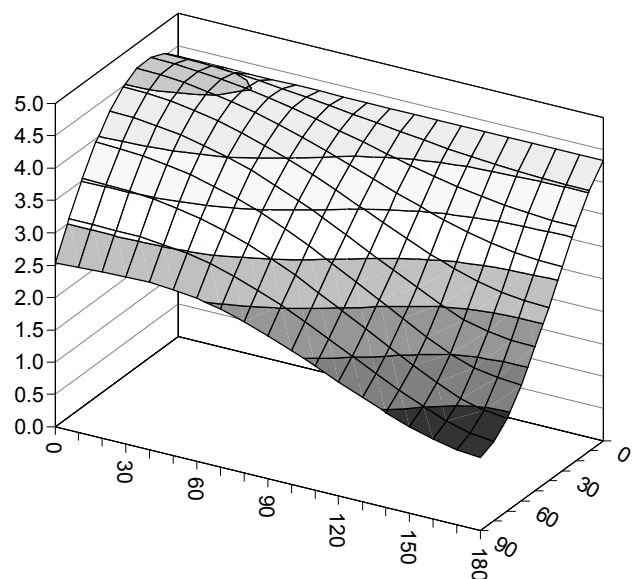

Fig. 2: Annual average irradiation on a plane in kWh/m<sup>2</sup> per day, as a function of the plane's orientation (x-axis) and tilt (y-axis) [Athens data].

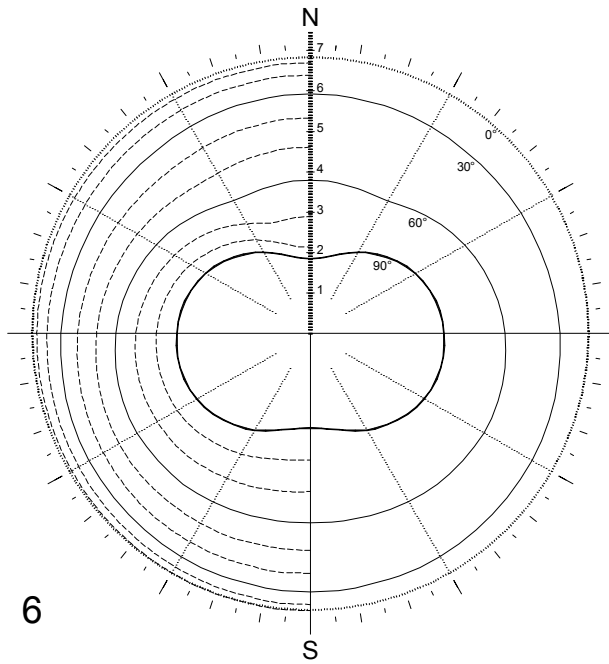

Fig. 3: *June* daily irradiation. Outer circle shows irradiation on horizontal ( $0^\circ$ ). Left and right halves are symmetrical; intermediate curves on the right half have been omitted for clarity. Legibility is improved by the use of colour in the original prints.

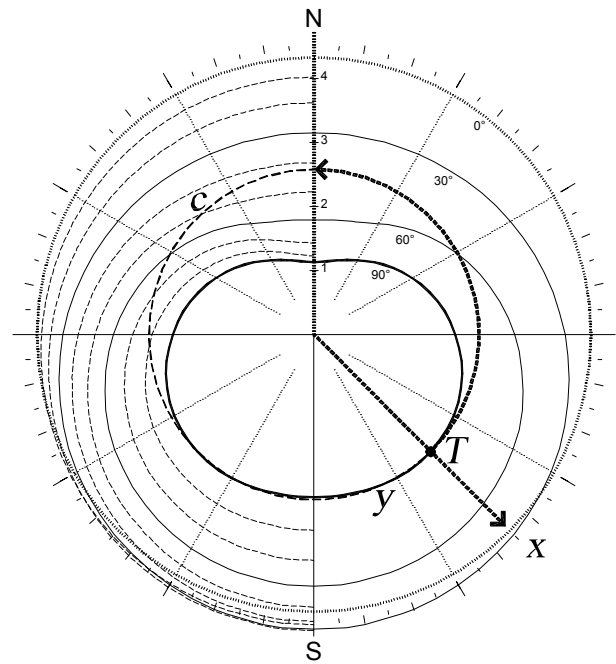

Fig. 4: *Annual* average daily irradiation. A radius of orientation  $x$  crosses curve for slope  $y$  at point  $T$ . The distance of  $T$  from the centre shows radiation rate. All points outside circle  $c$  indicate orientation & slope arrangements that receive more radiation than  $T$ .

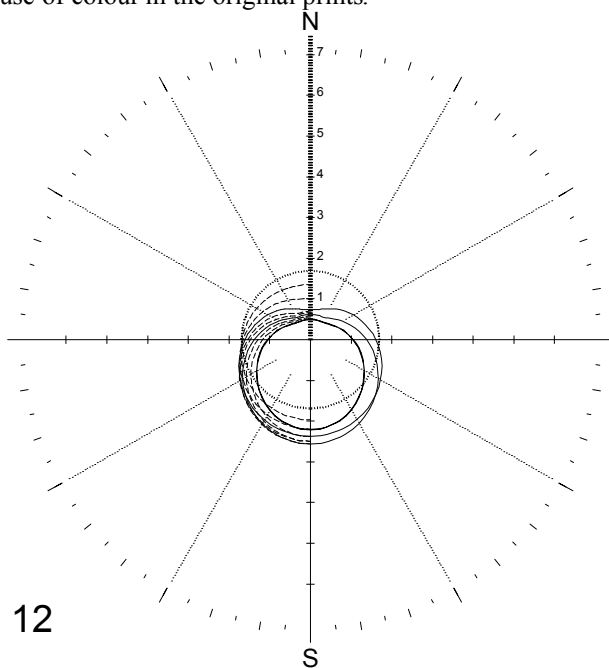

Fig. 5: *December* daily irradiation. The scale is the same as in Fig. 3, but due to low energy values, legibility is reduced.

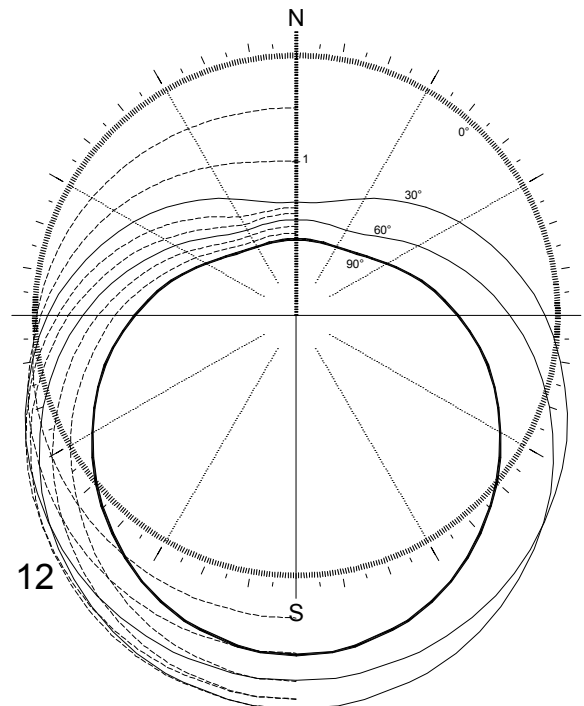

Fig. 6: Same data as in Fig. 5 but in larger scale for clarity. The radius of the  $0^\circ$  circle is identical to the ones in Figs. 3 & 4.

### 3.3 Reading the graphs

The graphs address questions like ‘*What is the daily irradiation on a plane of orientation  $x$  and slope  $y$  during month  $m$ ?*’. The user should use the graph of month  $m$  and draw a radius pointing at orientation  $x$ ; the radius crosses the curve for slope  $y$  at point  $T$  (interpolation between curves may be required). The distance of  $T$  from the centre corresponds to the daily radiation rate, which can be read in kWh/m<sup>2</sup> on the graphic scale marked along the north radius [Fig. 4]. Any point at longer distance from the centre indicates a layout (=orientation & slope) that receives more energy than  $T$ .

### 3.4 Scale

An important issue while preparing the graphs was their scale. By using the same scale for all months it is easier to compare radiation amounts from month to month [Fig. 7]. Winter graphs however are not easy to read due to small energy values and intermingling curves. In order to overcome this, the radius of the circle representing horizontal value (0° curve) is the same in all months, thus modifying the scale of each graph accordingly.

## 3. CONCLUSIONS

The irradiation graphs provide an easy tool to study the seasonal variations of solar intensity at various directions. In practical applications, they can facilitate the positioning of solar collectors in cases where a deviation from ‘optimum’ orientation and/or slope is required for various reasons. Furthermore, they can assist cooling design by providing data on the solar load of planes at any direction.

For the time being, the graphs (which are in camera-ready stage, waiting for publication funding) refer to global radiation in Athens only. Further work, supported by a sponsor, could encompass additional radiation types (direct & diffuse, under clear & overcast sky) and locations (radiation data similar to the ones used for Athens graphs has already been prepared for London & Riyadh, and for albedo 0, 0.2 & 1).

## REFERENCES

- Page, J K (ed.) (1986). *Prediction of solar radiation on inclined surfaces vol. 3*. Reidel/CEC  
Stasinopoulos, Thanos N (1999). *Geometric Forms & Insolation -an analytical study of the influence of shape on solar irradiation*. (PhD thesis, National Technical University of Athens; in Greek with English summary)

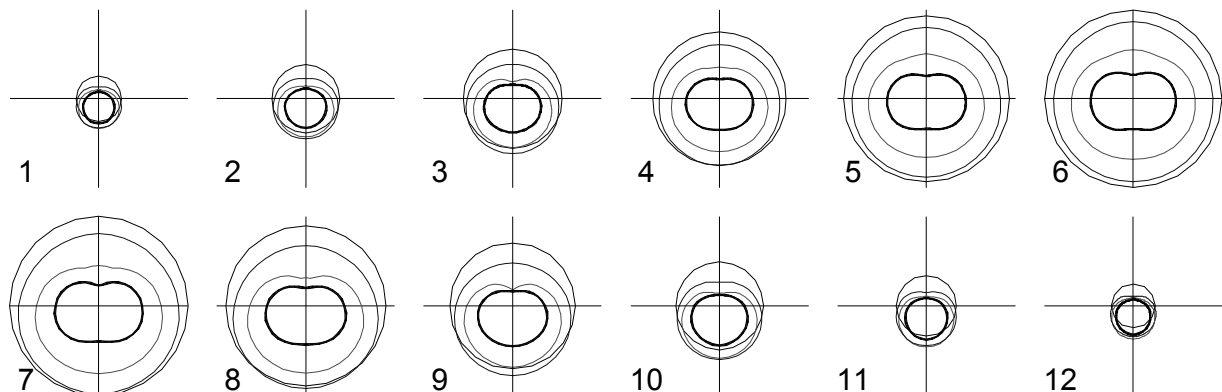

Fig. 7: Simplified example of monthly graphs, all at the same scale. Outer circle shows daily horizontal irradiation (slope=0°), thick curve refers to vertical planes (slope=90°), in-between curves are for 30 & 60° slopes. The size of each cross corresponds to the maximum monthly value (=June, horizontal).